



TEST REPORT NO.: RGT2025011600106

EMC TEST REPORT

ETSI EN 301 489-1 V2.2.3 (2019-11)

**Electromagnetic compatibility and Radio spectrum Matters (ERM);
Electro Magnetic Compatibility (EMC) standard for radio equipment and services;**

Part 1: Common technical requirements

ETSI EN 301 489-3 V2.3.2 (2023-01)

**Part 3: Specific conditions for Short Range Devices (SRD) operating on frequencies
between 9 kHz and 246 GHz; Harmonised Standard for Electro Magnetic Compatibility**

Name of applicant:	FOSHAN ONEHOME LIGHTING ELECTRONICS LIMITED
Business address:	Jinsha industry, Danzao town, NanHai district, Foshan City, Guangdong Province, China.
Prepared By:	Ring Testing Technology (zhongshan) Co., Ltd
Address:	Room 203, 2nd Floor, Building D, Wanwei Lighting Plaza, No.59 Tongxing Road, Guzhen Town, Zhongshan City, China.
Compiled by (+ signature):	Tuckwell Tan 
Approved by (+ signature):	Red Fan 
Date of issue:	2025-02-14
Number of pages:	43 Pages
Test item description	--
EUT:	CEILING LIGHT
Brand name:	 ONEHOME
Model number:	F0821001, F0812002, F0813003
Model Difference:	N/A
Rated power supply:	230V~, 50Hz, 60W
Name of manufacturer:	FOSHAN ONEHOME LIGHTING ELECTRONICS LIMITED
Business address:	Jinsha industry, Danzao town, NanHai district, Foshan City, Guangdong Province, China.
Test Result:	Pass
Test specifications:	ETSI EN 301 489-1 V2.2.3 (2019-11)
Standard	ETSI EN 301 489-3 V2.3.2 (2023-01)



The duplication of this report or parts of it and its use for advertising purposes is only allowed with permission of the testing laboratory. This report contains the result of the examination of the product sample submitted by the applicant. A general statement concerning the quality of The products from the series manufacture cannot be derived therefore.

Table of Contents

1. Revision History 3

2. Test Summary 4

3. Product Information And Test Setup 5

3.1. Product Information 5

3.2. Test Setup Configuration 5

3.3. Support Equipment 5

3.4. Test Mode 6

4. Test Facility And Test Instrument Used 7

4.1. Test Facility 7

4.2. Test Instrument Used 7

4.3. Testing software 9

4.4. Measurement Uncertainty 9

5. Conducted Emissions 10

5.1. Block Diagram Of Test Setup 10

5.2. Limit 10

5.3. Test procedure 10

5.4. Test Result 11

6. Radiated Emissions Test (30MHz-1000MHz) 13

6.1. Block Diagram Of Test Setup 13

6.2. Limits 14

6.3. Test Procedure 14

6.4. Test Results 15

7. Radiated Emissions Test (9KHz-30MHz)..... 17

7.1. Block Diagram Of Test Setup 17

7.2. Limits 17

7.3. Test Procedure 18

7.4. Test Results 18

8. Harmonic Current Emission(H) 22

8.1. Block Diagram of Test Setup 22

8.2. Limit 22

8.3. Test Procedure 22

8.4. Test Results 23

9. Voltage Fluctuations & Flicker(F) 24

9.1. Block Diagram of Test Setup 24

9.2. Limit 24

9.3. Test Procedure 24

9.4. Test Results 24

10. Immunity Test Of General The Performance Criteria 25

11. Electrostatic Discharge (ESD) 28

11.1. Test Specification 28

11.2. Block Diagram of Test Setup 28

11.3. Test Procedure 28

11.4. Test Results 29

12. Continuous RF Electromagnetic Field Disturbances(RS) 30

Report No.: RGT2025011600106

12.1. Test Specification	30
12.2. Block Diagram of Test Setup	30
12.3. Test Procedure	30
12.4. Test Results	31
13. Electrical Fast Transients/Burst (EFT/B)	32
13.1. Test Specification	32
13.2. Block Diagram of EUT Test Setup	32
13.3. Test Procedure	32
13.4. Test Results	32
14. Surges Immunity Test	33
14.1. Test Specification	33
14.2. Block Diagram of EUT Test Setup	33
14.3. Test Procedure	33
14.4. Test Result	34
15. Continuous Induced RF Disturbances (CS)	35
15.1. Test Specification	35
15.2. Block Diagram of EUT Test Setup	35
15.3. Test Procedure	35
15.4. Test Result	36
16. Voltage Dips And Interruptions (DIPS)	37
16.1. Test Specification	37
16.2. Block Diagram of EUT Test Setup	37
16.3. Test Procedure	37
16.4. Test Result	38
17. Photos Of Test Setup	39
18. EUT Photographs	43

1. Revision History

Version	Summary	Revision Date	Report No.
Ver.1.0	Original Report	2025-01-10	RGT2025011600106

2. Test Summary

The Product has been tested according to the following specifications:

ETSI EN 301 489-1 V2.2.3 (2019-11)

ETSI EN 301 489-3 V2.3.2 (2023-01)

EMISSION		
Standard	Test Item	Test result
EN 55032:2015 + A11:2020 + A1:2020	Conducted emissions from the AC mains power ports	Pass
EN 55032:2015 + A11:2020 + A1:2020	Asymmetric mode conducted emissions	N/A ¹
EN 55032:2015 + A11:2020 + A1:2020	Conducted differential voltage emissions	N/A ²
EN 55032:2015 + A11:2020 + A1:2020	Radiated emissions	Pass
EN IEC 61000-3-2:2019 + A1:2021 + A2:2024	Harmonic current emission(H)	Pass
EN 61000-3-3:2013 + A1:2019 + A2:2021	Voltage fluctuations & flicker(F)	Pass

IMMUNITY		
Standard	Test Item	Test result
EN 61000-4-2:2009	Electrostatic discharge (ESD)	Pass
EN 61000-4-3:2020	Continuous RF electromagnetic field disturbances (RS)	Pass
EN 61000-4-4:2012	Electrical fast transients/burst (EFT/B)	Pass
EN 61000-4-5:2014+A1:2017	Surges	Pass
EN 61000-4-6:2023	Radio frequency, common mode	Pass
EN 61000-4-11:2020	Voltage dips and interruptions (DIPS)	Pass

Remark:

"#" indicates the testing item(s) was (were) fulfilled by subcontracted lab.

1. Applicable to ports listed above and intended to connect to cables longer than 3 m.
2. The Product has no antenna port.
3. The Product belongs to Class A, and its power is less than 75W, so it deems to fulfil this standard without testing.
4. The Product is powered by the DC only, the test item is not applicable.

3. Product Information And Test Setup

3.1. Product Information

Product Name: CEILING LIGHT
 Test Model(s): F0821001, F0812002, F0813003
 Hardware Version: V1.0
 Software Version: V1.0
 Operation Frequency: 2402MHz
 Type of Modulation: GFSK
 Antenna installation: PCB Antenna
 Antenna Gain: 0dBi
 Power supply: Light: Input: AC 220-240V, 50/60Hz
 Remote control: DC 3V

Remark:

The antenna gain is provided by the customer, if the data provided by the customer is not accurate, Ring Testing Technology (zhongshan) Co., Ltd. does not assume any responsibility.

3.2. Test Setup Configuration

See test photographs attached in EUT TEST SETUP PHOTOGRAPHS for the actual connections between Product and support equipment.

3.3. Support Equipment

Item	Equipment	Mfr/Brand	Model/Type No.	Series No.	Note

Notes:

1. All the equipment/cables were placed in the worst-case configuration to maximize the emission during the test.
2. Grounding was established in accordance with the manufacturer's requirements and conditions for the intended use.

3.4. Test Mode

Test item	Test Mode	Test Voltage
Conducted emissions from the AC mains power ports (150KHz-30MHz) Class B	Working mode	AC 230V/50Hz
Radiated emissions(30MHz-6GHz) Class B	Working mode*	AC 230V/50Hz
Harmonic current emission(H) Class <u> A </u>	N/A	N/A
Voltage fluctuations & flicker(F)	Working mode	AC 230V/50Hz
Electrostatic discharge (ESD) <input checked="" type="checkbox"/> Air Discharge: ±2,4,8kV <input checked="" type="checkbox"/> Contact Discharge: ±2,4kV <input checked="" type="checkbox"/> HCP & VCP: ±2,4kV	Working mode	AC 230V/50Hz
Continuous RF electromagnetic field disturbances (RS) <input checked="" type="checkbox"/> 80MHz-6000MHz, 3V/m,80%	Working mode	AC 230V/50Hz
Electrical fast transients/burst (EFT/B) <input checked="" type="checkbox"/> 1kVAC (Input) <input type="checkbox"/> 0.5kV DC(Input) <input type="checkbox"/> 0.5kV signal,Telec,control	Working mode	AC 230V/50Hz
Surges <input checked="" type="checkbox"/> 1kV Line-Line, <input type="checkbox"/> 2kV Line-PE, N-PE <input type="checkbox"/> 0.5kVDC (Input) <input type="checkbox"/> 1KV, <input type="checkbox"/> 4KV signal,Telec, control Line-Line:90°+1kV,270°-1kV Line-PE:90°+2kV,270°-2kV N-PE:90°-2kV,270°+2kV	Working mode	AC 230V/50Hz
Continuous induced RF disturbances (CS) 0.15MHz to 10MHz 3V,10MHz-30MHz 3 to 1V,30MHz-80MHz 1V <input checked="" type="checkbox"/> AC (Input) <input type="checkbox"/> DC(Input) <input type="checkbox"/> signal,control	Working mode	AC 230V/50Hz
Voltage dips and interruptions (DIPS) <input checked="" type="checkbox"/> Less 5% 0.5P <input checked="" type="checkbox"/> 70% 500ms Voltage Interruptions <input checked="" type="checkbox"/> less5% 5000ms	Working mode	AC 230V/50Hz

All test mode were tested and passed.

4. Test Facility And Test Instrument Used

4.1. Test Facility

Test site 1:

Ring Testing Technology (zhongshan) Co., Ltd

Room 203, 2nd Floor, Building D, Wanwei Lighting Plaza, No.59 Tongxing Road, Guzhen Town, Zhongshan City, China.

Test site 2:

Shenzhen Haiyun Testing Co., Ltd.

No. 2 Danzi North Road, Kengzi Street, Pingshan District, Shenzhen, Guangdong, China

4.2. Test Instrument Used

Conducted emissions Test

Equipment	Manufacturer	Model	Last Cal.	Next Cal.
Receiver	R&S	ESCI	May 10, 2024	May 09, 2025
LISN	R&S	ENV216	May 10, 2024	May 09, 2025
ISN CAT 6	Schwarzbeck	NTFM 8158	May 10, 2024	May 09, 2025
ISN CAT 5	Schwarzbeck	CAT5 8158	May 10, 2024	May 09, 2025
Capacitive Voltage Probe	Schwarzbeck	CVP 9222 C	May 10, 2024	May 09, 2025
Current Transformer Clamp	Schwarzbeck	SW 9605	May 10, 2024	May 09, 2025
CE Shielding Room	EMToni	9m4m3m	May 10, 2024	May 09, 2025

Radiated emissions Test

Equipment	Manufacturer	Model	Last Cal.	Next Cal.
Receiver	R&S	ESCI	May 10, 2024	May 09, 2025
Loop antenna	EMCI	LAP600	May 10, 2024	May 09, 2025
Amplifier	Schwarzbeck	BBV 9743 B	May 10, 2024	May 09, 2025
Amplifier	Schwarzbeck	BBV 9718 B	May 10, 2024	May 09, 2025
Bilog Antenna	Schwarzbeck	VUXMSJ9162	May 28, 2024	May 27, 2025
Horn Antenna	Schwarzbeck	BBHA9120D	May 16, 2024	May 15, 2025

Report No.: RGT2025011600106

Horn Antenna	A.H.SYSTEMS	SAS574	May 10, 2024	May 09, 2025
--------------	-------------	--------	--------------	--------------

Amplifier	AEROFLEX	100KHz-40GHz	May 10, 2024	May 09, 2025
Spectrum Analyzer	R&S	FSV40	May 10, 2024	May 09, 2025
966 Anechoic Chamber	EMToni	9m6m6m	Nov. 25, 2022	Nov. 24, 2025

Harmonic / Flicker Test

Equipment	Manufacturer	Model	Last Cal.	Next Cal.
Power Analyzer	Li	AC2000A	May 10, 2024	May 09, 2025

Electrostatic discharge immunity Test

Equipment	Manufacturer	Model	Last Cal.	Next Cal.
ESD TEST Generator	HTEC	HESD16	May 10, 2024	May 09, 2025

Fast transients and Surges and Voltage dips and short interruptions Test

Equipment	Manufacturer	Model	Last Cal.	Next Cal.
Surge Generator	HTEC	HCOMPACT5/HV1 P6T	May 10, 2024	May 09, 2025
DIPS Generator	HTEC	HCOMPACT5/HV1 P6T	May 10, 2024	May 09, 2025
EFT/B Generator	HTEC	HCOMPACT5/HV1 P6T	May 10, 2024	May 09, 2025
EFT/B Clamp	HTEC	H3C	May 10, 2024	May 09, 2025

Injected currents Test

Equipment	Manufacturer	Model	Last Cal.	Next Cal.
Signal Generator	Schwarzbeck	CDG 7000-25	May 10, 2024	May 09, 2025
Attenuator	Schwarzbeck	6db	May 10, 2024	May 09, 2025
CDN	Schwarzbeck	CDN M2+M3-16A	May 10, 2024	May 09, 2025
CDN T8	HTEC	CDN T8-10	May 10, 2024	May 09, 2025

Radio-frequency electromagnetic fields Test(Site2)

Equipment	Manufacturer	Model	Last Cal.	Next Cal.
Signal generator	DARE	CTR1009B/RGN6000B	Oct. 16, 2024	Oct. 15, 2025
Power meter	DARE	RPR2006C	Oct. 16, 2024	Oct. 15, 2025
Power meter	DARE	RPR2006C	Oct. 16, 2024	Oct. 15, 2025
Power amplifier	Bonn	BLWA0820-200/100	Oct. 16, 2024	Oct. 15, 2025
Integral Antenna	DARE	RFS2006B	Oct. 16, 2024	Oct. 15, 2025
Integral Antenna	Schwarzbeck	STLP 9128D	Oct. 16, 2024	Oct. 15, 2025

4.3. Testing software

Project	Software name	Edition
Conducted Emission	EZ-EMC	EMC-CON 3A1.1+
Radiated electromagnetic disturbances	EZ-EMC	EMC-CON 3A1.1+
Disturbance Power Emission	EZ-EMC	EMC-CON 3A1.1+
Radiated Emission	EZ-EMC	FA-03A2 RE+
Conducted Susceptibility	IEC/EN 61000-4-6	1.4.1
Voltage changes, voltage fluctuations and flicker	Harmonic	121
RF Test	MTS 8310	2.0.0.0

4.4. Measurement Uncertainty

Where relevant, the following measurement uncertainty levels have been estimated for tests performed on the Product as specified in CISPR 16-4-2. This uncertainty represents an expanded uncertainty expressed at approximately the 95% confidence level using a coverage factor of k=2.

Test item	Value (dB)
Conducted Emission (150kHz-30MHz)	2.60
Radiated Emission(30MHz~1GHz)	5.89
Radiated Emission(1GHz~6GHz)	4.48

5. Conducted Emissions

5.1. Block Diagram Of Test Setup

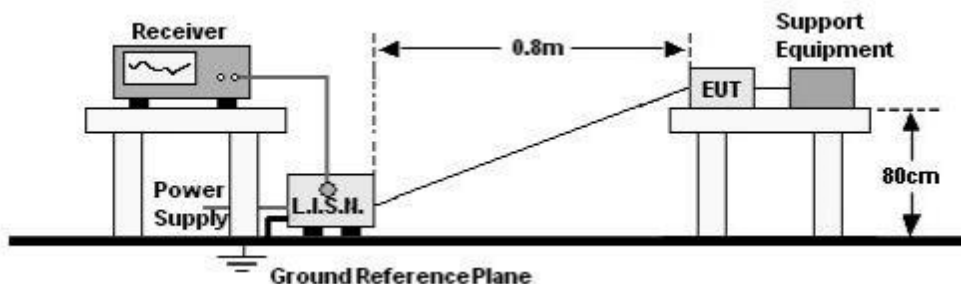

5.2. Limit

Limits for Conducted emissions at the mains ports of Class B MME

Frequency range (MHz)	Limits dB(μV)	
	Quasi-peak	Average
0,15 to 0,50	66 to 56*	56 to 46*
0,50 to 5	56	46
5 to 30	60	50

Notes: 1. *Decreasing linearly with logarithm of frequency.
2. The lower limit shall apply at the transition frequencies.

5.3. Test procedure

- The Product was placed on a nonconductive table 0.8m above the horizontal ground reference plane, and 0.4 m from the vertical ground reference plane, and connected to the main through Line Impedance Stability Network (L.I.S.N).
- The RBW of the receiver was set at 9 kHz in 150 kHz ~ 30MHz with Peak and AVG detector in Max Hold mode. Run the receiver's pre-scan to record the maximum disturbance generated from Product in all power lines in the full band.
- For each frequency whose maximum record was higher or close to limit, measure its QP and AVG values and record.

5.4. Test Result

Temperature:	24.1 °C	Relative Humidity:	54%
Pressure:	101.4kPa	Phase:	Live
Test Mode	Working mode	Remark:	N/A

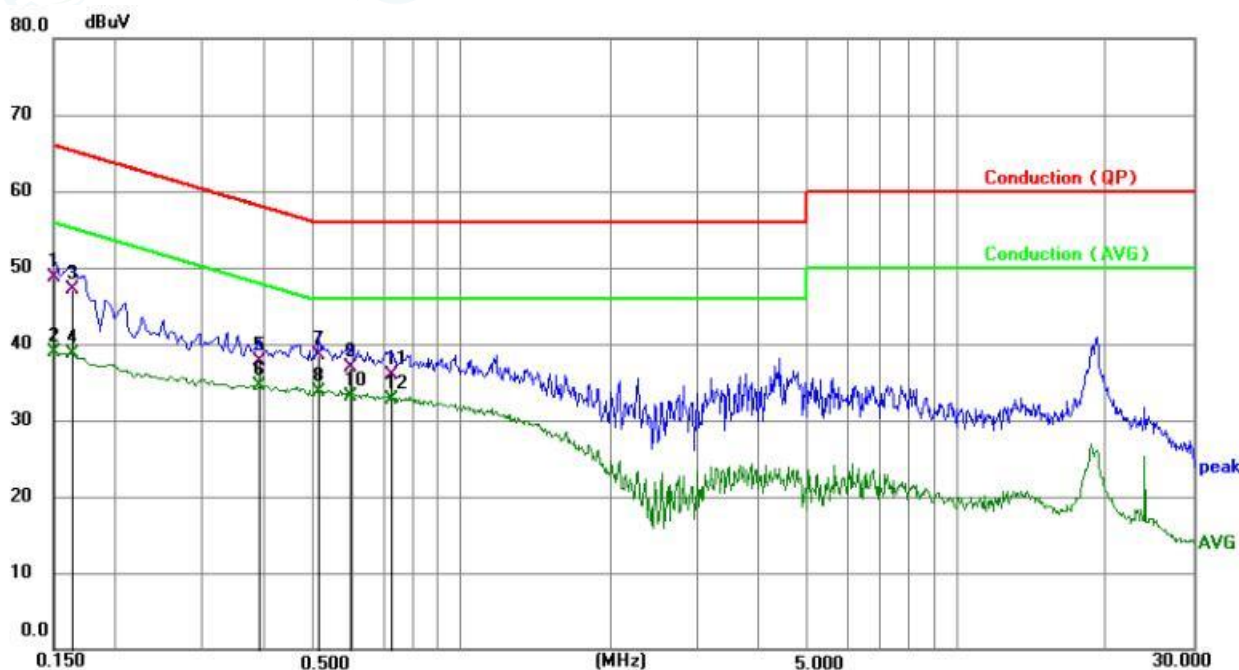

No.	Frequency (MHz)	Reading (dBuV)	Factor (dB)	Level (dBuV)	Limit (dBuV)	Margin (dB)	Detector	P/F	Remark
1	0.1500	38.75	9.89	48.64	66.00	-17.36	QP	P	
2	0.1500	28.96	9.89	38.85	56.00	-17.15	AVG	P	
3	0.1635	37.22	9.90	47.12	65.28	-18.16	QP	P	
4	0.1635	28.85	9.90	38.75	55.28	-16.53	AVG	P	
5	0.3885	27.81	9.98	37.79	58.10	-20.31	QP	P	
6	0.3885	24.54	9.98	34.52	48.10	-13.58	AVG	P	
7	0.5144	28.44	10.02	38.46	56.00	-17.54	QP	P	
8 *	0.5144	23.60	10.02	33.62	46.00	-12.38	AVG	P	
9	0.5955	26.78	10.03	36.81	56.00	-19.19	QP	P	
10	0.5955	23.12	10.03	33.15	46.00	-12.85	AVG	P	
11	0.7260	25.96	10.04	36.00	56.00	-20.00	QP	P	
12	0.7260	22.73	10.04	32.77	46.00	-13.23	AVG	P	

Temperature:	24.1 °C	Relative Humidity:	54%
Pressure:	101.4kPa	Phase:	Neutral
Test Mode	Working mode	Remark:	N/A

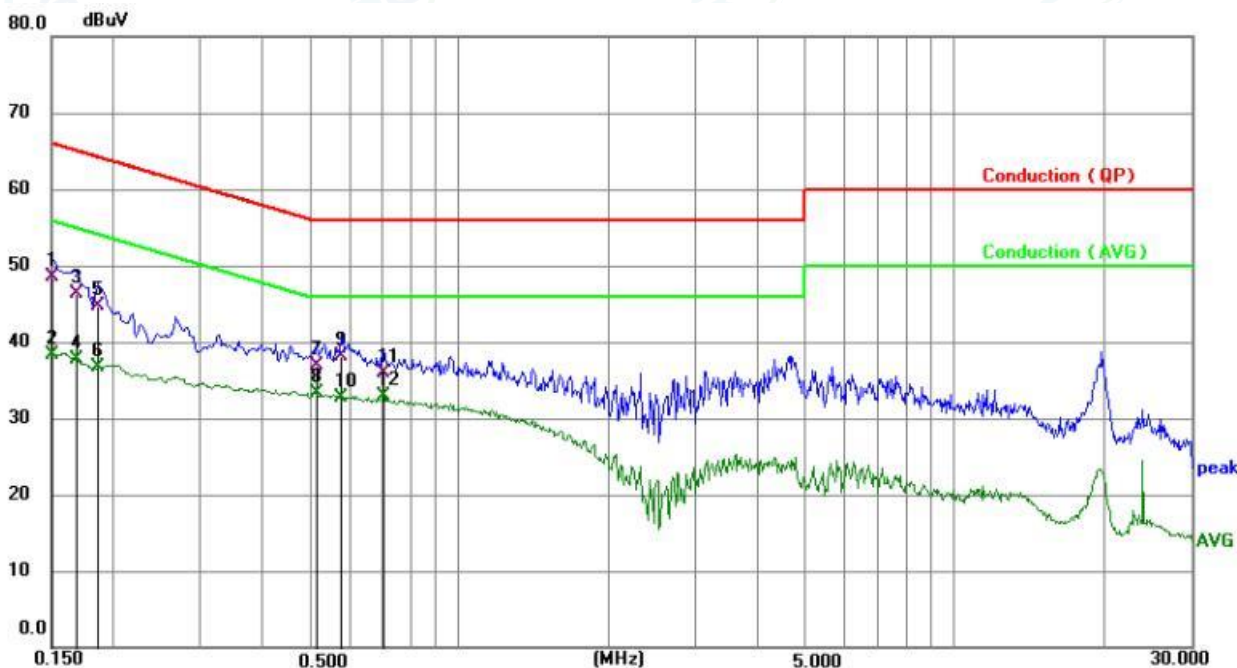

No.	Frequency (MHz)	Reading (dBuV)	Factor (dB)	Level (dBuV)	Limit (dBuV)	Margin (dB)	Detector	P/F	Remark
1	0.1500	38.64	9.89	48.53	66.00	-17.47	QP	P	
2	0.1500	28.49	9.89	38.38	56.00	-17.62	AVG	P	
3	0.1680	36.50	9.90	46.40	65.06	-18.66	QP	P	
4	0.1680	27.72	9.90	37.62	55.06	-17.44	AVG	P	
5	0.1860	34.80	9.90	44.70	64.21	-19.51	QP	P	
6	0.1860	26.74	9.90	36.64	54.21	-17.57	AVG	P	
7	0.5144	26.95	10.02	36.97	56.00	-19.03	QP	P	
8 *	0.5144	23.36	10.02	33.38	46.00	-12.62	AVG	P	
9	0.5775	28.01	10.03	38.04	56.00	-17.96	QP	P	
10	0.5775	22.61	10.03	32.64	46.00	-13.36	AVG	P	
11	0.7035	25.87	10.04	35.91	56.00	-20.09	QP	P	
12	0.7035	22.77	10.04	32.81	46.00	-13.19	AVG	P	

Remark: Level=Reading +Factor

Margin=Level -Limit

6. Radiated Emissions Test

6.1. Block Diagram Of Test Setup

30MHz ~ 1GHz:

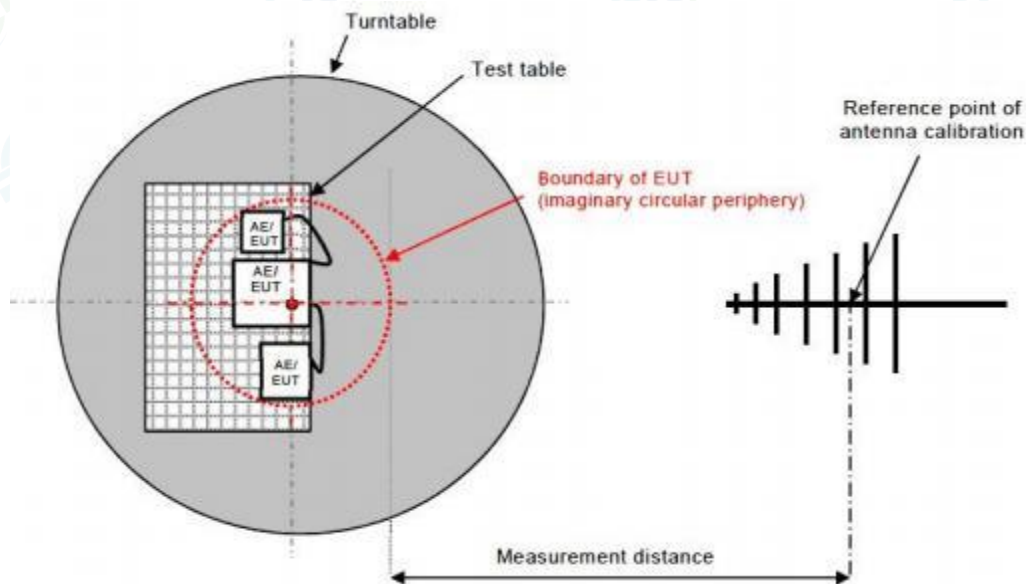

Above 1GHz:

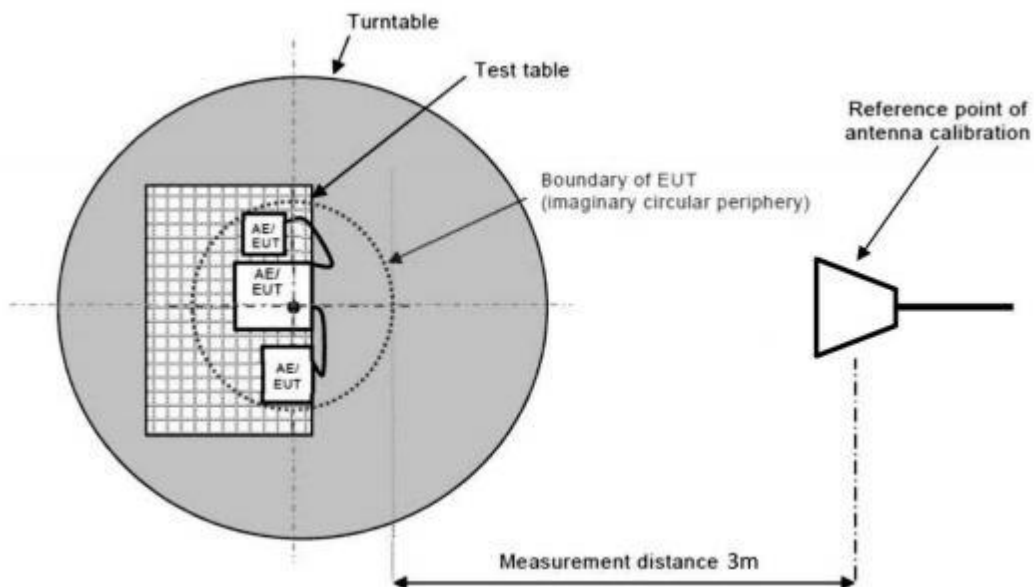

6.2. Limits

Limits for radiated disturbance of Class B MME

Frequency (MHz)	Quasi-peak limits at 3m dB(μV/m)
30-230	40
230-1000	47

Frequency (GHz)	limit above 1G at 3m dB(μV/m)	
	Average	peak
1-3	50	70
3-6	54	74

Note: The lower limit shall apply at the transition frequencies.

6.3. Test Procedure

30MHz ~ 1GHz:

- a. The Product was placed on the nonconductive turntable 0.8m above the ground in a semi anechoic chamber.
- b. Set the spectrum analyzer/receiver in Peak detector, Max Hold mode, and 120 kHz RBW. Record the maximum field strength of all the pre-scan process in the full band when the antenna is varied between 1~4 m in both horizontal and vertical, and the turntable is rotated from 0 to 360 degrees.
- c. For each frequency whose maximum record was higher or close to limit, measure its QP value: vary the antenna's height and rotate the turntable from 0 to 360 degrees to find the height and degree where Product radiated the maximum emission, then set the test frequency analyzer/receiver to QP Detector and specified bandwidth with Maximum Hold Mode, and record the maximum value.

Above 1GHz:

- a. The Product was placed on the non-conductive turntable 0.8m above the ground in a full anechoic chamber..
- b. Set the spectrum analyzer/receiver in Peak detector, Max Hold mode, and 1MHz RBW. Record the maximum field strength of all the pre-scan process in the full band when the antenna is varied in both horizontal and vertical, and the turntable is rotated from 0 to 360 degrees.
- c. For each frequency whose maximum record was higher or close to limit, measure its AV value: rotate the turntable from 0 to 360 degrees to find the degree where Product radiated the maximum emission, then set the test frequency analyzer/receiver to AV value and specified bandwidth with Maximum Hold Mode, and record the maximum value.

6.4. Test Results

30MHz-1GHz

Temperature:	24.3 °C	Relative Humidity:	53%
Pressure:	101.4kPa	Polarization:	Horizontal
Test Mode	Working mode	Remark:	N/A

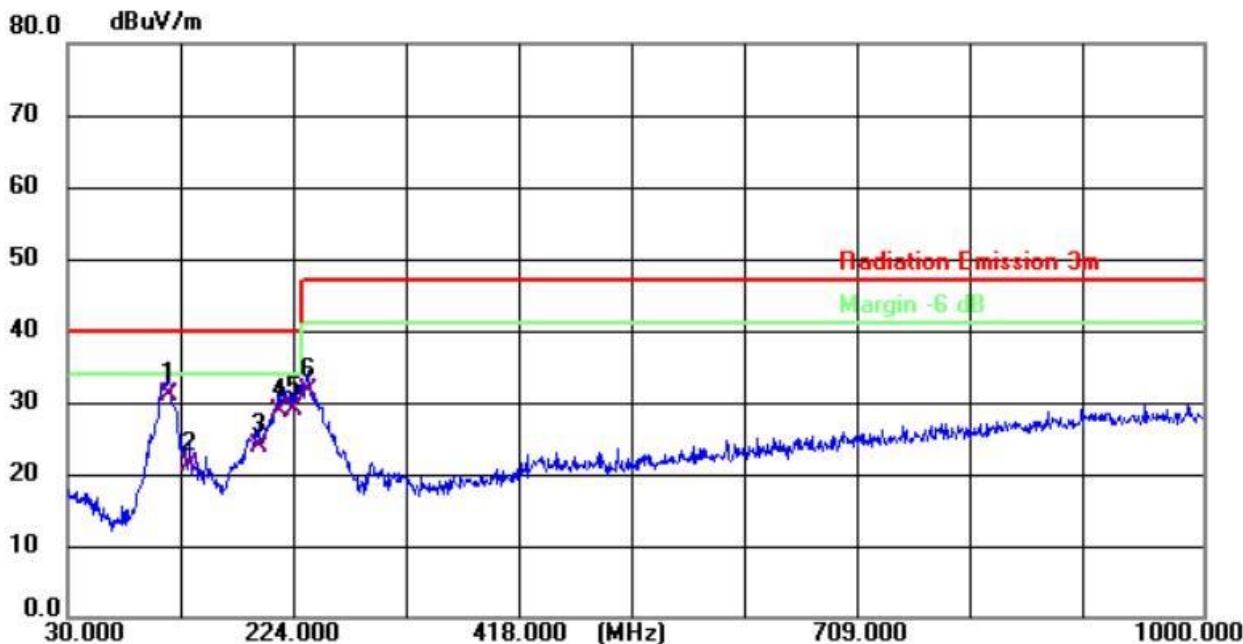

No.	Frequency (MHz)	Reading (dBuV)	Factor (dB/m)	Level (dBuV/m)	Limit (dBuV/m)	Margin (dB)	Detector
1 *	116.330	43.56	-12.61	30.95	40.00	-9.05	QP
2	134.760	34.69	-13.52	21.17	40.00	-18.83	QP
3	192.960	35.61	-11.62	23.99	40.00	-16.01	QP
4	210.420	39.43	-10.75	28.68	40.00	-11.32	QP
5	223.030	39.36	-10.27	29.09	40.00	-10.91	QP
6	235.640	41.29	-9.80	31.49	47.00	-15.51	QP

Temperature:	24.3 °C	Relative Humidity:	53%
Pressure:	101.4kPa	Polarization:	Vertical
Test Mode	Working mode	Remark:	N/A

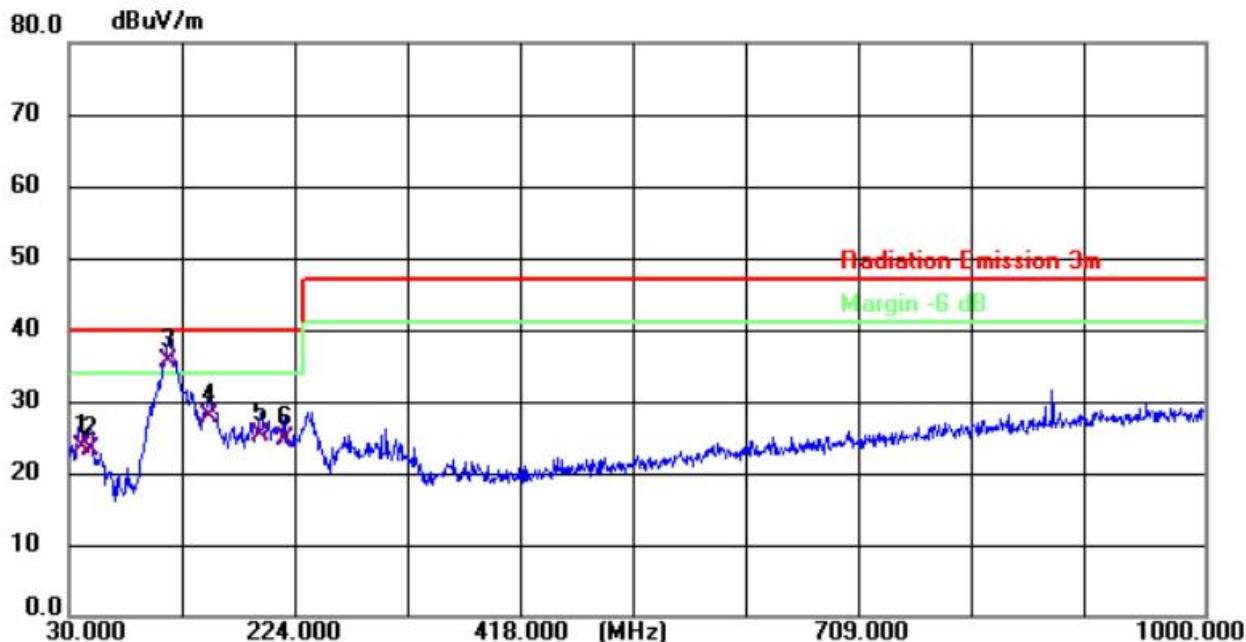

No.	Frequency (MHz)	Reading (dBuV)	Factor (dB/m)	Level (dBuV/m)	Limit (dBuV/m)	Margin (dB)	Detector
1	40.670	32.21	-8.60	23.61	40.00	-16.39	QP
2	48.430	32.54	-9.22	23.32	40.00	-16.68	QP
3 *	115.360	48.16	-12.53	35.63	40.00	-4.37	QP
4	149.310	41.95	-14.12	27.83	40.00	-12.17	QP
5	192.960	36.92	-11.62	25.30	40.00	-14.70	QP
6	215.270	35.36	-10.57	24.79	40.00	-15.21	QP

Remark: Level=Reading +Factor
Margin=Level -Limit

Above 1G

The amplitude of spurious emissions which are attenuated by more than 20dB below the permissible value has no need to be reported

7. RADIATED ELECTROMAGNETIC DISTURBANCES (9kHzTo30MHz)

MEASUREMENT

7.1 Block Diagram of Test Setup

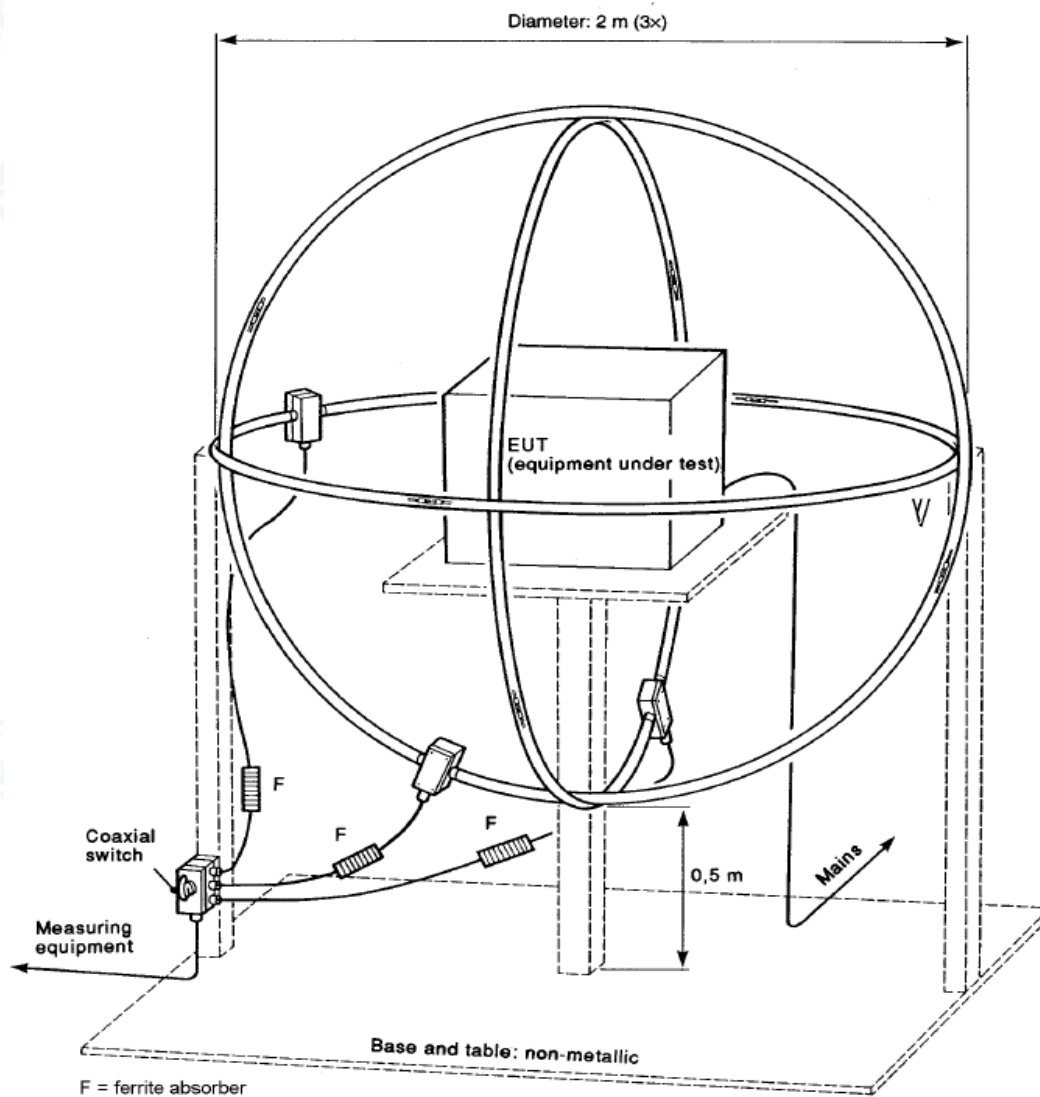

7.2 Radiated electromagnetic disturbances (9kHz to 30MHz) Measurement Limits

Frequency	Limits for loop diameter (dB μ A)	
	2m	
9kHz ~ 70kHz	88	
70kHz ~ 150kHz	88 ~ 58*	
150kHz ~ 3.0MHz	58 ~ 22*	
3.0MHz ~ 30MHz	22	

1. At the transition frequency the lower limit applies.

2. * decreasing linearly with logarithm of the frequency.

7.3 Operating Condition of EUT

7.3.1 Setup the EUT as shown in Section 6.1.

7.3.2 Turn on the power.

7.3.3 Let the EUT work in test mode (ON) and measure it.

7.4 Test Procedure

The EUT is placed on a wood table in the center of a loop antenna. The induced current in the loop antenna is measured by means of a current probe and the test receiver.

Three field components are checked by means of a coaxial switch.

The frequency range from 9kHz to 30MHz is investigated. The receiver is measured with the quasi-peak detector. For frequency band 9kHz to 150kHz, the bandwidth of the field strength meter (R&S test receiver ESCS30) is set at 200Hz. For frequency band 150kHz to 30MHz, the bandwidth is set at 9kHz.

7.5 Test Results

PASS.

The frequency range from 9kHz to 30MHz is investigated.

The test data are attached in the following pages.

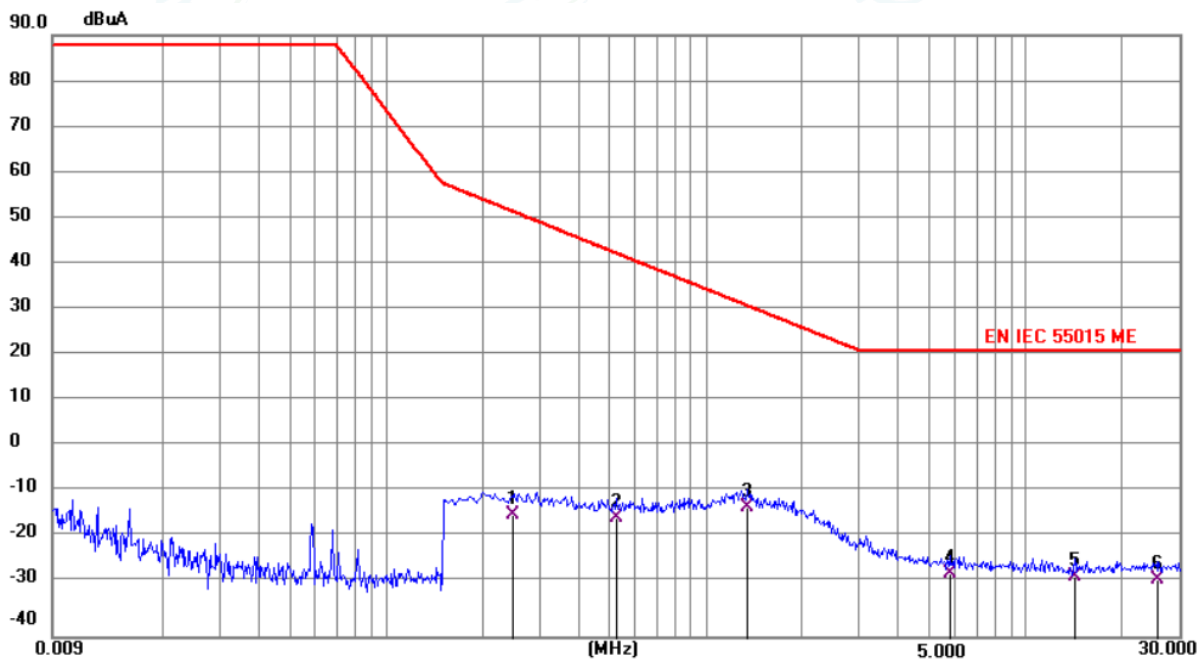

No.	Frequency (MHz)	Reading (dBuA)	Factor (dB)	Level (dBuA)	Limit (dBuA)	Margin (dB)	Detector	P/F	Remark
1	0.2444	-13.63	0.10	-13.53	52.13	-65.66	QP	P	
2	0.5235	-14.14	0.10	-14.04	42.98	-57.02	QP	P	
3 *	1.3334	-12.03	0.11	-11.92	31.74	-43.66	QP	P	
4	5.7705	-26.28	0.14	-26.14	22.00	-48.14	QP	P	
5	14.1450	-27.10	0.19	-26.91	22.00	-48.91	QP	P	
6	25.5975	-27.71	0.27	-27.44	22.00	-49.44	QP	P	

Model	F0821001
Operating Mode	Cold white, maximum power, Fan ON with max Speed
Antenna	LOOP X
Test voltage	230V~, 50Hz
Test Date	2024-11-25



No.	Frequency (MHz)	Reading (dBuA)	Factor (dB)	Level (dBuA)	Limit (dBuA)	Margin (dB)	Detector	P/F	Remark
1	0.1635	-14.39	0.10	-14.29	56.96	-71.25	QP	P	
2	0.4560	-14.21	0.10	-14.11	44.64	-58.75	QP	P	
3	1.2615	-12.59	0.11	-12.48	32.41	-44.89	QP	P	
4 *	1.5900	-12.53	0.11	-12.42	29.63	-42.05	QP	P	
5	6.1260	-24.23	0.14	-24.09	22.00	-46.09	QP	P	
6	23.1855	-27.82	0.25	-27.57	22.00	-49.57	QP	P	

Model	F0821001
Operating Mode	Cold white, maximun power, Fan ON with max Speed
Antenna	LOOP Y
Test voltage	230V~, 50Hz
Test Date	2024-11-25

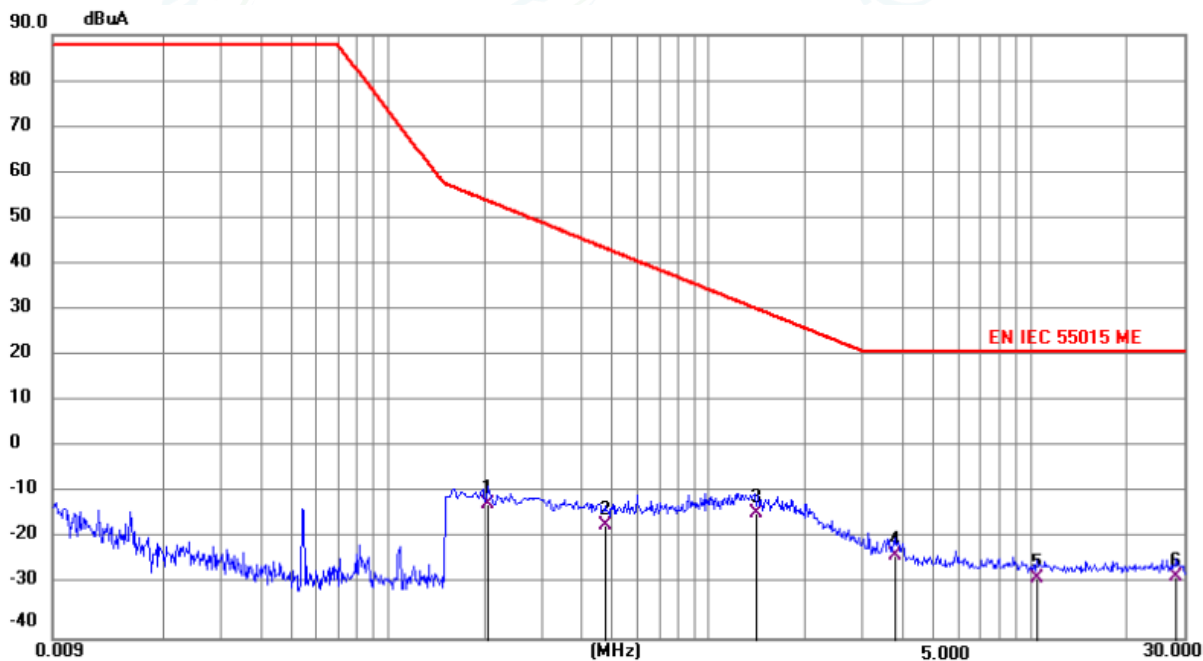

No.	Frequency (MHz)	Reading (dBuA)	Factor (dB)	Level (dBuA)	Limit (dBuA)	Margin (dB)	Detector	P/F	Remark
1	0.2040	-11.12	0.10	-11.02	54.30	-65.32	QP	P	
2	0.4740	-15.44	0.10	-15.34	44.17	-59.51	QP	P	
3 *	1.4144	-12.92	0.11	-12.81	31.04	-43.85	QP	P	
4	3.7905	-22.21	0.13	-22.08	22.00	-44.08	QP	P	
5	10.5135	-27.06	0.17	-26.89	22.00	-48.89	QP	P	
6	28.4820	-26.77	0.29	-26.48	22.00	-48.48	QP	P	

Model	F0821001
Operating Mode	Cold white, maximum power, Fan ON with max Speed
Antenna	LOOP Z
Test voltage	230V~, 50Hz
Test Date	2024-11-25

8. Harmonic Current Emission(H)

8.1. Block Diagram of Test Setup

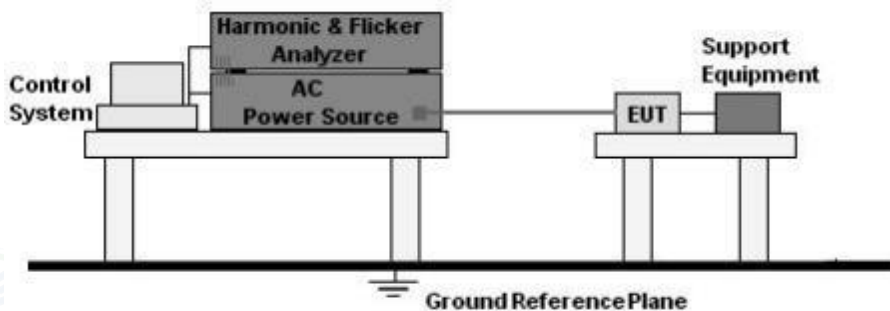

8.2. Limit

EN IEC 61000-3-2: 2019 + A1: 2021 + A2:2024.

8.3. Test Procedure

- The Product was placed on the top of a non-conductive table above the ground and operated to produce the maximum harmonic components under normal operating conditions for each successive harmonic component in turn.
- The correspondent test program of test instrument to measure the current harmonics emanated from Product was chosen. The measure time shall be not less than the time necessary for the Product to be exercised.

8.4. Test Results

Test Result: **Pass**

Source qualification(Power Off Load): **Idle - Pass**

Current & voltage waveforms

Waveform Graph

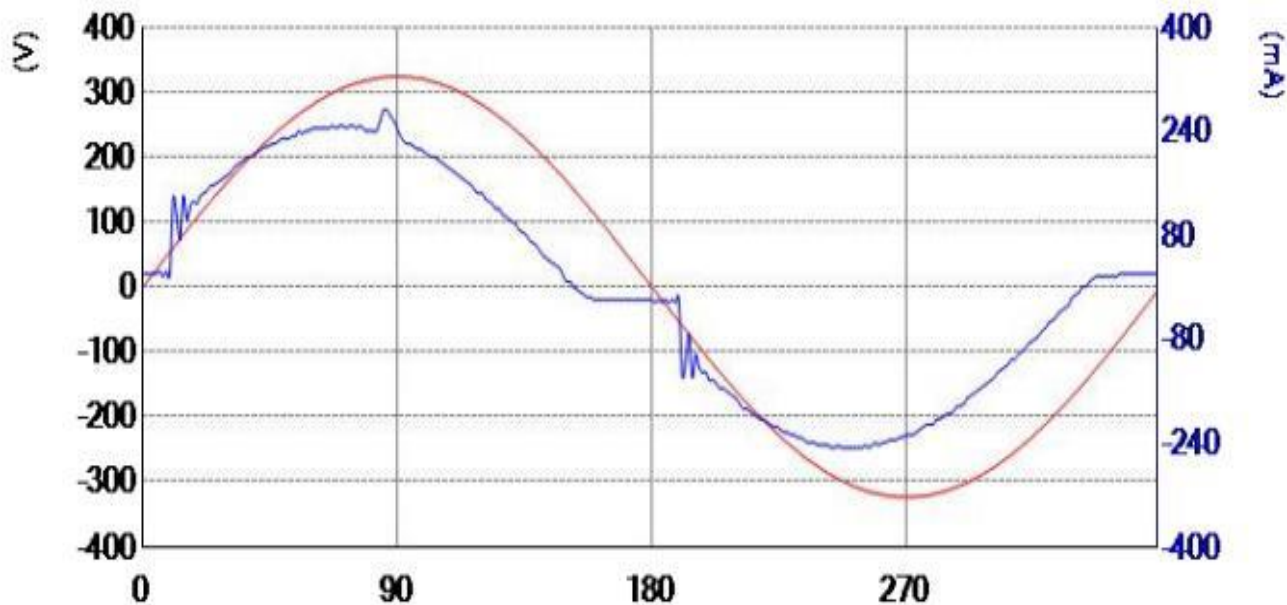

Harmonics and Class C limit line (>25W)

Harmonics Histogram

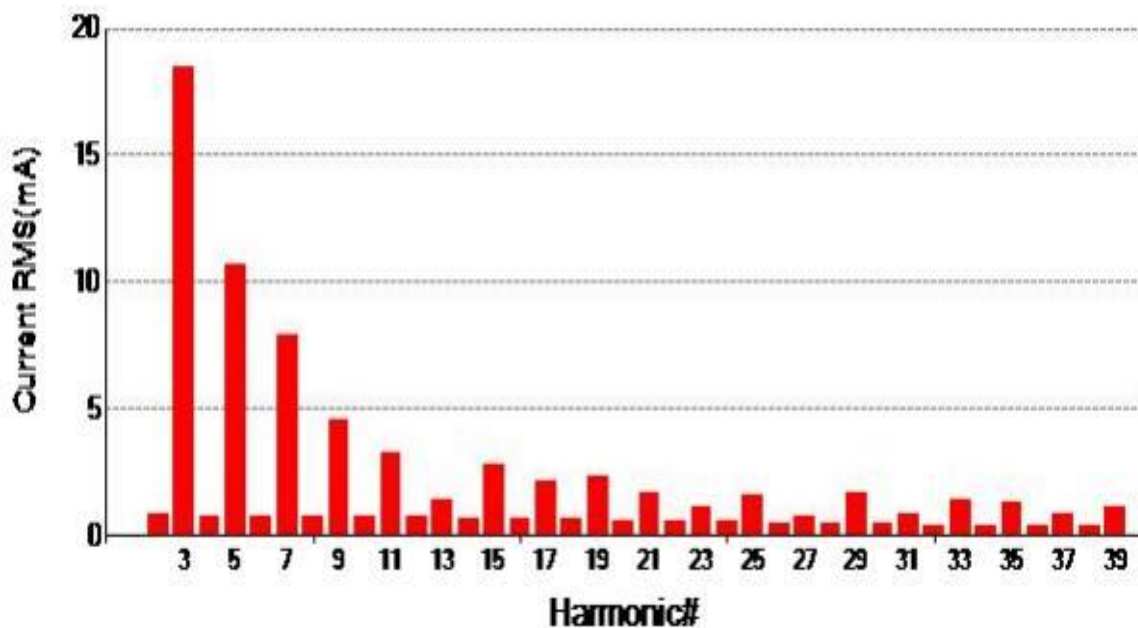

9. Voltage Fluctuations & Flicker(F)

9.1. Block Diagram of Test Setup

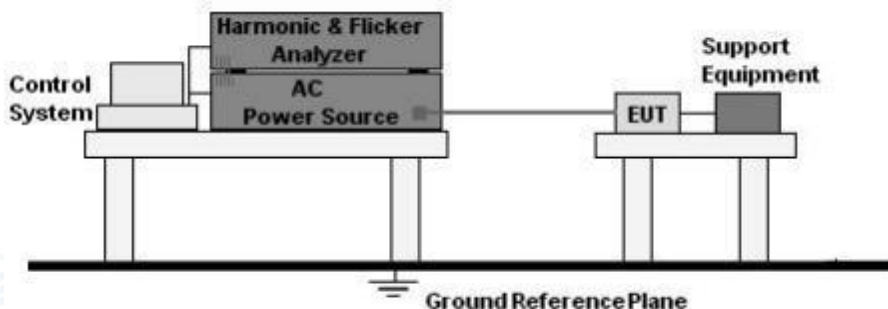

9.2. Limit

EN 61000-3-3: 2013 + A1:2019 + A2: 2021.

9.3. Test Procedure

- The Product was placed on the top of a non-conductive table above the ground and operated to produce the most unfavorable sequence of voltage changes under normal operating conditions.
- During the flick test, the measure time shall include that part of whole operation cycle in which the Product produce the most unfavorable sequence of voltage changes. The observation period for short-term flicker indicator is 10 minutes and the observation period for long-term flicker indicator is 2 hours.

9.4. Test Results

Pass

Remark: Through technical analysis and evaluation, EUT power is very small, and it is unlikely to cause significant voltage fluctuation or flicker. Therefore, the requirements can be met without testing.

10. Immunity Test Of General The Performance Criteria

Product Standard	ETSI EN 301 489-1
	<p>The performance criteria are used to take a decision on whether a radio equipment passes or fails immunity tests.</p> <p>For the purpose of the present document two categories of performance criteria apply:</p> <ul style="list-style-type: none"> • Performance criteria for continuous phenomena. • Performance criteria for transient phenomena. <p>NOTE: Normally, the performance criteria depends upon the type of radio equipment and/or its intended application. Thus, the present document only contains general performance criteria commonly used for the assessment of radio equipment.</p>
<p>Performance criteria for continuous phenomena</p>	<p>During the test, the equipment shall:</p> <ul style="list-style-type: none"> • continue to operate as intended; • not unintentionally transmit; • not unintentionally change its operating state; • not unintentionally change critical stored data.
<p>Performance criteria for transient phenomena</p>	<p>For all ports and transient phenomena with the exception described below, the following applies:</p> <ul style="list-style-type: none"> • The application of the transient phenomena shall not result in a change of the mode of operation (e.g. unintended transmission) or the loss of critical stored data. • After application of the transient phenomena, the equipment shall operate as intended. <p>For surges applied to symmetrically operated wired network ports intended to be connected directly to outdoor lines the following criteria applies:</p> <ul style="list-style-type: none"> • For products with only one symmetrical port intended for connection to outdoor lines, loss of function is allowed, provided the function is self-recoverable, or can be otherwise restored. Information stored in non-volatile memory, or protected by a battery backup, shall not be lost. • For products with more than one symmetrical port intended for connection to outdoor lines, loss of function on the port under test is allowed, provided the function is self-recoverable. Information stored in non-volatile memory, or protected by a battery backup, shall not be lost.

Report No.: RGT2025011600106

According To EN 301489 - 17 standard, The General Performance Criteria As Following:

General performance criteria

The performance criteria are:

- performance criteria A for immunity tests with phenomena of a continuous nature;
- performance criteria B for immunity tests with phenomena of a transient nature;
- performance criteria C for immunity tests with power interruptions exceeding a certain time.

The equipment shall meet the minimum performance criteria as specified in the following clauses.

Table 1: Performance criteria

Criteria	During the test	After test (i.e. as a result of the application of the test)
A	Shall operate as intended. (see note). Shall be no loss of function. Shall be no unintentional transmissions.	Shall operate as intended. Shall be no degradation of performance. Shall be no loss of function. Shall be no loss of critical stored data.
B	May be loss of function.	Functions shall be self-recoverable. Shall operate as intended after recovering. Shall be no loss of critical stored data.
C	May be loss of function.	Functions shall be recoverable by the operator Shall operate as intended after recovering Shall be no degradation of performance.
NOTE: Operate as intended during the test allows a level of degradation in accordance with clause 6.2.2.		

Minimum performance level

For equipment that supports a PER or FER, the minimum performance level shall be a PER or FER less than or equal to 10 %.

For equipment that does not support a PER or a FER, the minimum performance level shall be no loss of the wireless transmission function needed for the intended use of the equipment.

Performance criteria for Continuous phenomena applied to Transmitters (CT)

The performance criteria B shall apply, except for voltage dips of 100 ms and voltage The performance criteria Ashall apply.

Tests shall be repeated with the EUT in standby mode (if applicable) to ensure that unintentional transmission does not occur. In systems using acknowledgement signals, it is recognized that an ACKnowledgement (ACK) or Not ACKnowledgement (NACK) transmission may occur, and steps should be taken to ensure that any transmission resulting from the application of the test is correctly interpreted.

Performance criteria for Transient phenomena applied to Transmitters (TT)

The performance criteria B shall apply, except for voltage dips of 100 ms and voltage interruptions of 5 000 ms duration, for which performance criteria C shall apply.

Tests shall be repeated with the EUT in standby mode (if applicable) to ensure that unintentional transmission does not occur. In systems using acknowledgement signals, it is recognized that an acknowledgement (ACK) or not-acknowledgement (NACK) transmission may occur, and steps should be taken to ensure that any transmission resulting from the application of the test is correctly interpreted.

Performance criteria for Continuous phenomena applied to Receivers (CR)

The performance criteria Ashall apply.

Where the EUT is a transceiver, under no circumstances, shall the transmitter operate unintentionally during the test. In systems using acknowledgement signals, it is recognized that an ACK or NACK transmission may occur, and steps should be taken to ensure that any transmission resulting from the application of the test is correctly interpreted.

Performance criteria for Transient phenomena applied to Receivers (TR)

The performance criteria B shall apply, except for voltage dips of 100 ms and voltage interruptions of 5 000 ms duration for which performance criteria C shall apply.

Where the EUT is a transceiver, under no circumstances, shall the transmitter operate unintentionally during the test. In systems using acknowledgement signals, it is recognized that an ACK or NACK transmission may occur, and steps should be taken to ensure that any transmission resulting from the application of the test is correctly interpreted.

11. Electrostatic Discharge (ESD)

11.1. Test Specification

Test Port	:	Enclosure port
Discharge Impedance	:	330 ohm / 150 pF
Discharge Mode	:	Single Discharge
Discharge Period	:	one second between each discharge

11.2. Block Diagram of Test Setup

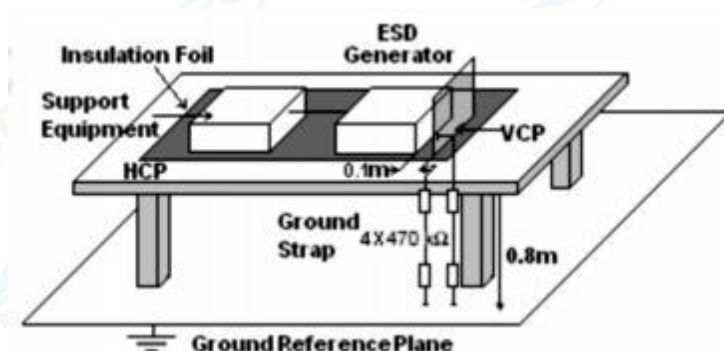

11.3. Test Procedure

- Electrostatic discharges were applied only to those points and surfaces of the Product that are accessible to users during normal operation.
- The test was performed with at least ten single discharges on the pre-selected points in the most sensitive polarity.
- The time interval between two successive single discharges was at least 1 second.
- The ESD generator was held perpendicularly to the surface to which the discharge was applied and the return cable was at least 0.2 meters from the Product.
- Contact discharges were applied to the non-insulating coating, with the pointed tip of the generator penetrating the coating and contacting the conducting substrate.
- Air discharges were applied with the round discharge tip of the discharge electrode approaching the Product as fast as possible (without causing mechanical damage) to touch the Product. After each discharge, the ESD generator was removed from the Product and re-triggered for a new single discharge. The test was repeated until all discharges were complete.

Report No.: RGT2025011600106

g. At least ten single discharges (in the most sensitive polarity) were applied to the Horizontal Coupling Plane at points on each side of the Product. The ESD generator was positioned vertically at a distance of 0.1 meters from the Product with the discharge electrode touching the HCP.

h. At least ten single discharges (in the most sensitive polarity) were applied to the center of one vertical edge of the Vertical Coupling Plane in sufficiently different positions that the four faces of the Product were completely illuminated. The VCP (dimensions 0.5m x 0.5m) was placed vertically to and 0.1 meters from the Product.

11.4. Test Results

Temperature :	24.2°C	Relative Humidity :	54.0%
Pressure :	101.4kPa	Test Mode :	Working mode

Discharge Method	Discharge Position	Voltage (±kV)	Min. No. of Discharge per polarity (Each Point)	Performance Criterion	Result
Contact Discharge	Conductive Surfaces	±2, ±4	10	B	A
	Indirect Discharge HCP	±2, ±4	10	B	A
	Indirect Discharge VCP	±2, ±4	10	B	A
Air Discharge	Slots, Apertures, and Insulating Surfaces	±2, ±4, ±8	10	B	A

Note: A: No performance degradation during test.

B: During the test, the EUT shut down, after the test, it reset by itself.

C: During the test, the EUT shut down, after the test, it reset by user.

12. Continuous RF Electromagnetic Field Disturbances(RS)

12.1. Test Specification

Test Port	::::	Enclosure port
Step Size	:	1%
Modulation		1kHz, 80% AM
Dwell Time		1 second
Polarization		Horizontal & Vertical

12.2. Block Diagram of Test Setup

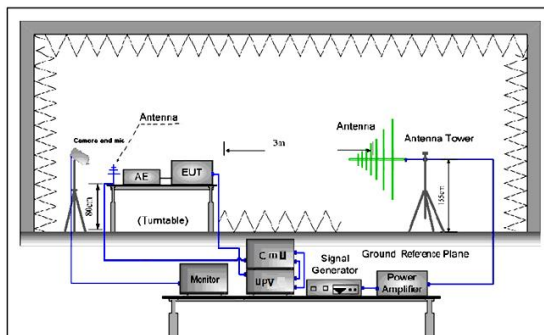

Figure 1. 80MHz to 1GHz

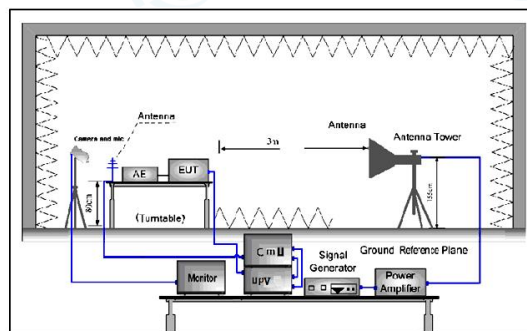

Figure 2. 1GHz to 6GHz

12.3. Test Procedure

- The testing was performed in a fully-anechoic chamber. The transmit antenna was located at a distance of 3 meters from the Product.
- The frequency range is swept from 80MHz to 6000MHz, with the signal 80% amplitude modulated with a 1 kHz sine wave, and the step size was 1%.
- The dwell time at each frequency shall not be less than the time necessary for the EUT to be exercised and to be able to respond, but should not exceed 5 s at each of the frequencies during the scan.
- The test was performed with the Product exposed to both vertically and horizontally polarized fields on each of the four sides.
- For Broadcast reception function: Group 2 not apply in this test.

12.4. Test Results

Temperature :	23.6 °C	Relative Humidity :	51%
Pressure :	101.4kPa	Test Mode :	Working mode

Frequency	Position	Field Strength (V/m)	Performance Criterion	Result
80 - 6000MHz	Front, Right, Back, Left	3	A	A

Note: A: No performance degradation during test.

B: This item is tested by Shenzhen Haiyun Testing Co., Ltd.

13. Electrical Fast Transients/Burst (EFT/B)

13.1. Test Specification

Test Port	: input a.c. power port
Impulse Frequency	: 5 kHz
Impulse Wave-shape	: 5/50 ns
Burst Duration	: 15 ms
Burst Period	: 300 ms
Test Duration	: 2 minutes per polarity

13.2. Block Diagram of EUT Test Setup

For input a.c. power port:

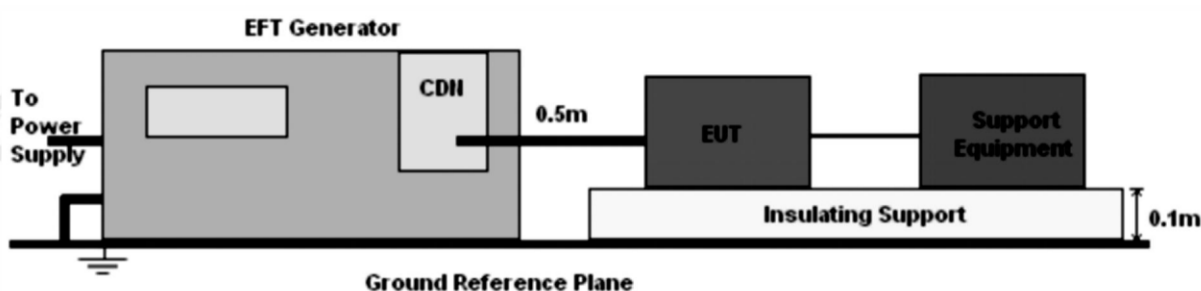

13.3. Test Procedure

- The Product and support units were located on a non-conductive table above ground reference plane.
- A 0.5m-long power cord was attached to Product during the test.

13.4. Test Results

Temperature :	24.0 °C	Relative Humidity :	53.1%
Pressure :	101.4kPa	Test Mode :	Working mode

Coupling	Voltage (kV)	Polarity	Performance Criterion	Result
AC MainsL-N	1.0	±	B	A
Signal Line	0.5	±	B	N/A
Telec Ports	0.5	±	B	N/A
DC Ports	0.5	±	B	N/A

Note: A: No performance degradation during test.
 B: During the test, the EUT shut down, after the test, it reset by itself.
 C: During the test, the EUT shut down, after the test, it reset by user.

14. Surges Immunity Test

14.1. Test Specification

Test Port	: input a.c. power port
Wave-Shape	: Open Circuit Voltage - 1.2 / 50 μ s Short Circuit Current - 8 / 20 μ s
Pulse Repetition Rate	: 1 pulse / min.
Phase Angle	: 0° / 90° / 180° / 270°
Test Events	: 5 pulses (positive & negative) for each polarity

14.2. Block Diagram of EUT Test Setup

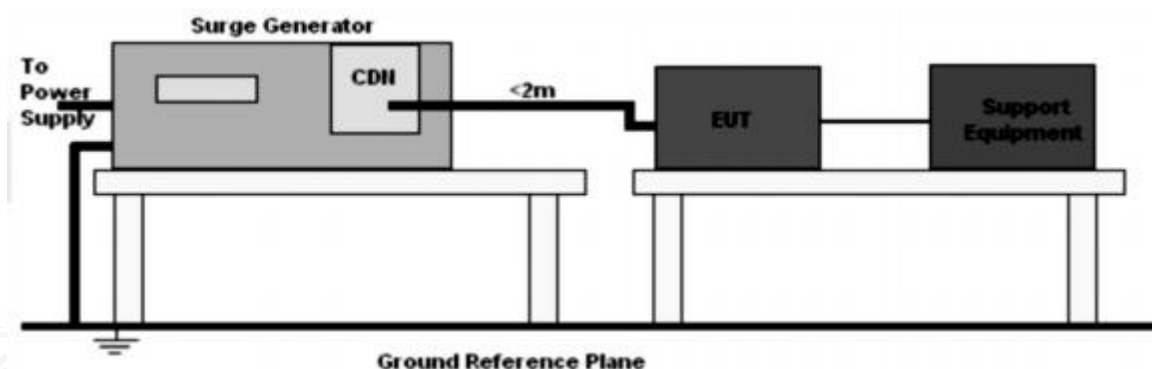

14.3. Test Procedure

- The surge is to be applied to the Product power supply terminals via the capacitive coupling network. Decoupling networks are required in order to avoid possible adverse effects on equipment not under test that may be powered by the same lines, and to provide sufficient decoupling impedance to the surge wave.
- The power cord between the Product and the coupling/decoupling networks shall be 2 meters in length (or shorter). Interconnection line between the Product and the coupling/decoupling networks shall be 2 meters in length (or shorter).

14.4. Test Result

Temperature :	24.0 °C	Relative Humidity :	53.1%
Pressure :	101.4kPa	Test Mode :	Working mode

Coupling Line	Voltage (kV)	Polarity	Performance Criterion	Result
L - N	1	±	B	A
L - PE	2	±	B	N/A
N - PE	2	±	B	N/A
LAN Ports	±1	/	B	N/A

Note: A: No performance degradation during test.
 B: During the test, the EUT shut down, after the test, it reset by itself.
 C: During the test, the EUT shut down, after the test, it reset by user.

Remark: No test shall be required where normal functioning cannot be achieved because of the impact of the CDN on the Product.

15. Continuous Induced RF Disturbances (CS)

15.1. Test Specification

Test Port	:	input a.c. power port
Step Size	:	1%
Modulation	:	1kHz, 80% AM
Dwell Time	:	1 second

15.2. Block Diagram of EUT Test Setup

For input a.c. power port:

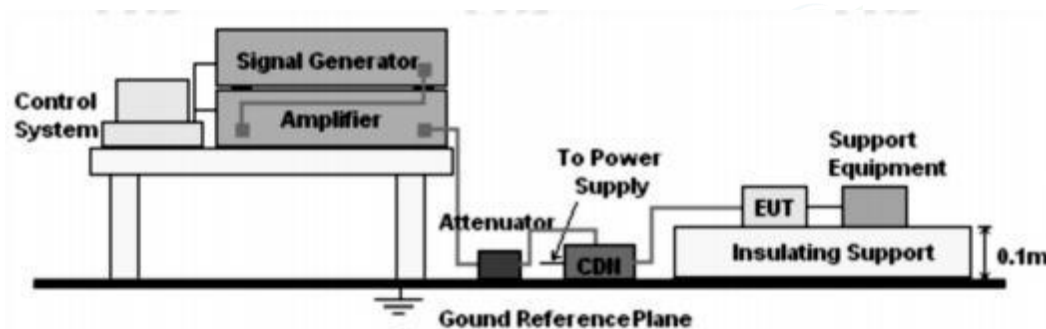

15.3. Test Procedure

For input a.c. power port:

- The Product and support units were located at a ground reference plane with the interposition of a 0.1 m thickness insulating support and the CDN was located on GRP directly.
- The frequency range is swept from 150 kHz to 10MHz, 10MHz to 30MHz, 30MHz to 80MHz with the signal 80% amplitude modulated with a 1 kHz sine wave, and the step size was 1% of fundamental.
- The dwell time at each frequency shall be not less than the time necessary for the Product to be able to respond.

15.4. Test Result

Temperature :	24.0 °C	Relative Humidity :	53.1%
Pressure :	101.4kPa	Test Mode :	Working mode

Inject Line	Frequency (MHz)	Voltage Level (V r.m.s.)	Performance Criterion	Result
a.c. port	0.15 - 80	3	A	A
Signal Line	0.15 - 80	3	N/A	N/A
Telec Ports	0.15 - 80	3	N/A	N/A
DC Ports	0.15 - 80	3	N/A	N/A

Note: A: No performance degradation during test.

16. Voltage Dips And Interruptions (DIPS)

16.1. Test Specification

Test Port	:	input a.c. power port
Phase Angle	:	0°, 180°
Test cycle	:	3 times

16.2. Block Diagram of EUT Test Setup

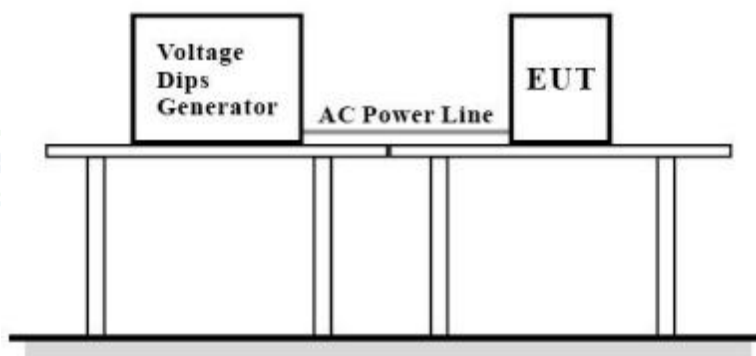

16.3. Test Procedure

- The Product and support units were located on a non-conductive table above ground floor.
- Set the parameter of tests and then perform the test software of test simulator.
- Conditions changes to occur at 0 degree crossover point of the voltage waveform.

16.4. Test Result

Temperature :	24.0 °C	Relative Humidity :	53.1%
Pressure :	101.4kPa	Test Mode :	Working mode

Voltage Dips:				
Test Level % U_T	Voltage dips in % U_T	Duration (ms)	Performance Criterion	Result
0	100	10	B	A
0	100	20	B	A
70	30	500	C	A
Voltage Interruptions:				
0	100	5000	C	C
Note: A: No performance degradation during test. B: During the test, the EUT shut down, after the test, it reset by itself. C: During the test, the EUT shut down, after the test, it reset by user.				

17. Photos Of Test Setup

CE



RE

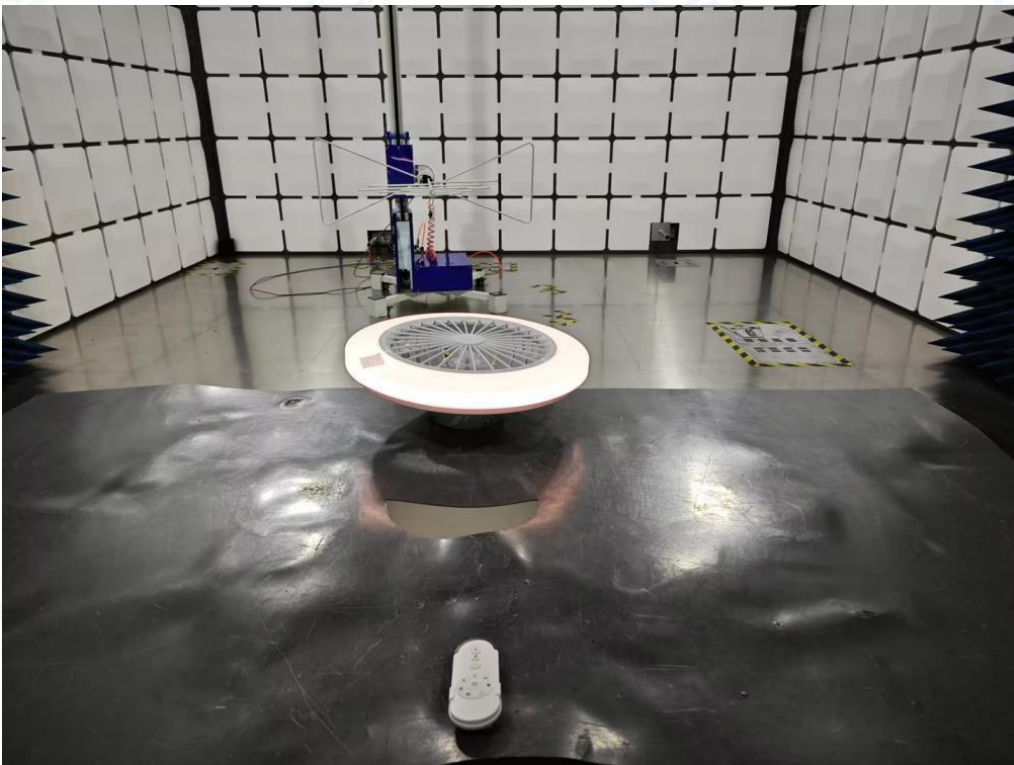

LOOP



Harmonic



ESD

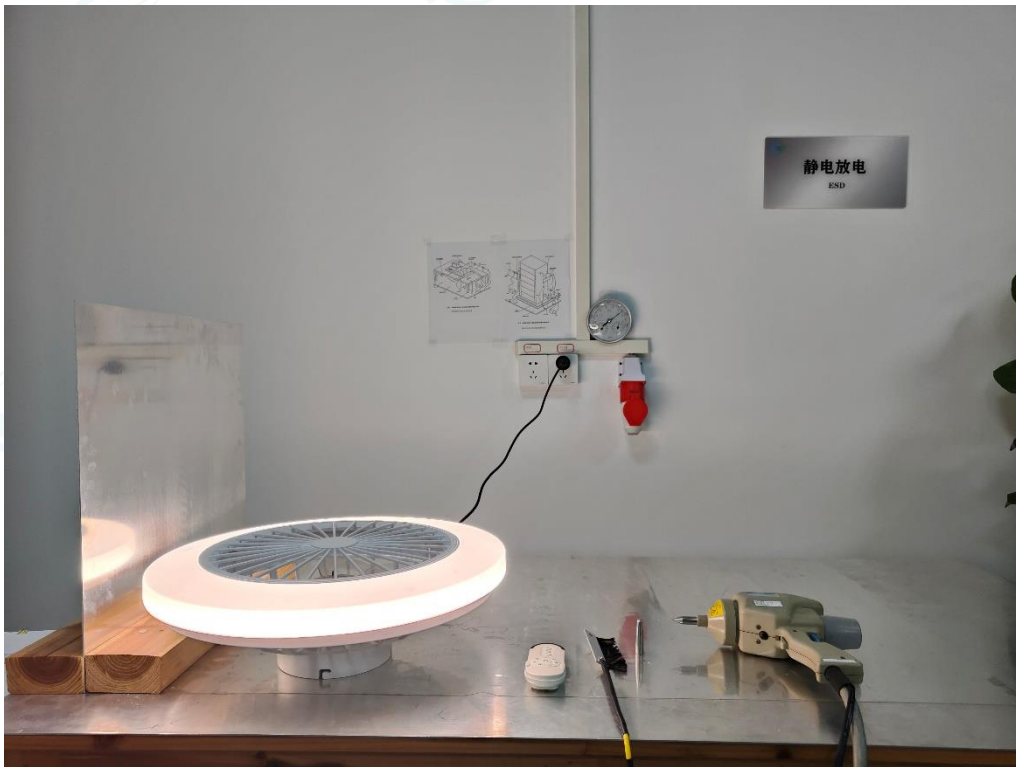

EFT

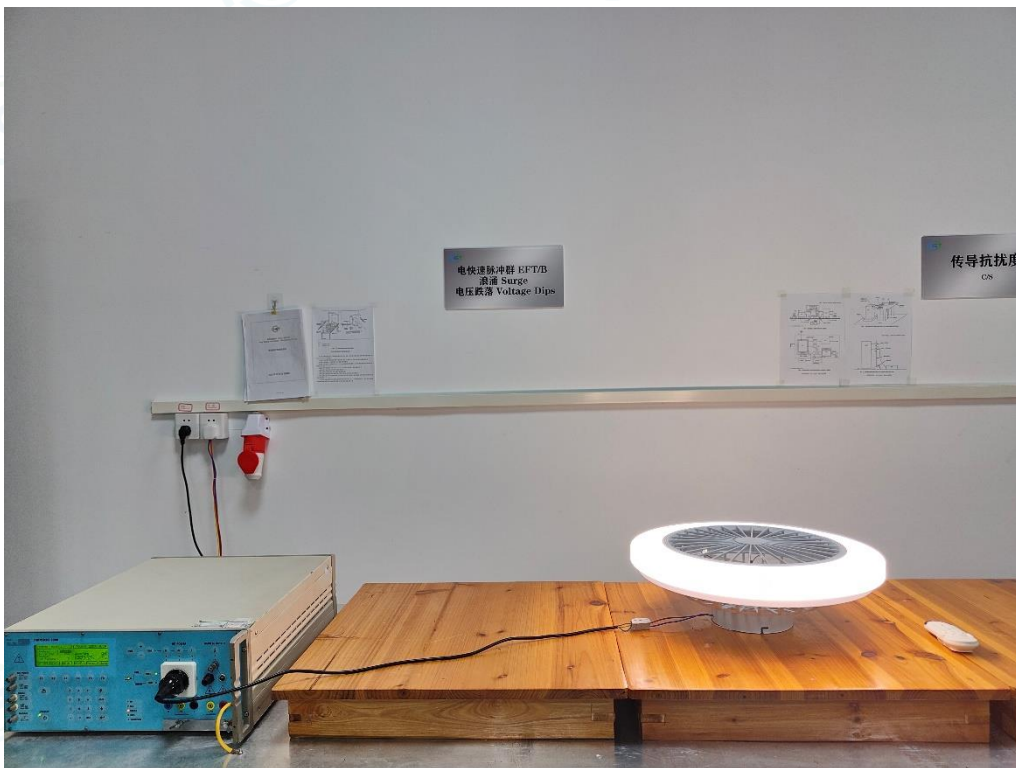

CS

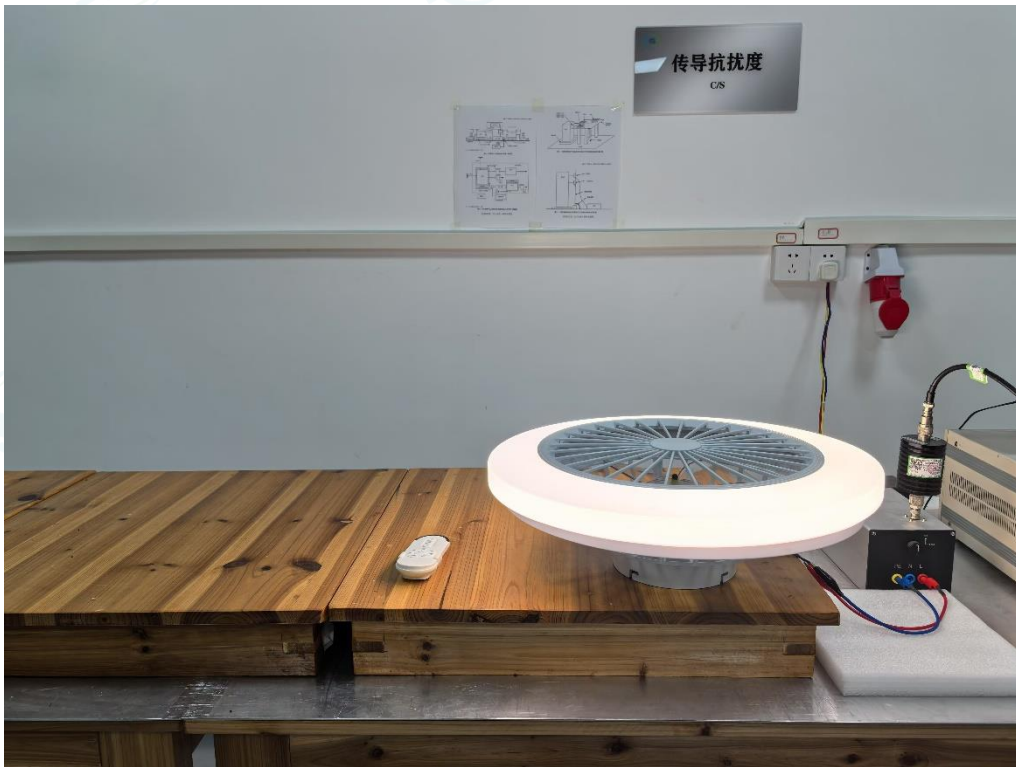

V-DIPS & SURGE



18. EUT Photographs

Reference to the RGT2025011600106-E1 for details.

*****End of report*****